

# PA Loudspeaker System Design Using Multiphysics Simulation

R. Balistreri

QSC Audio Products LLC, Research and Development, Costa Mesa, CA, USA

**Introduction:** Public Address Loudspeakers need extra design considerations if compared with normal speakers. Coverage over a certain frequency range it is important and COMSOL has the capabilities to do a whole system design simulation keeping prototype times at a minimum.

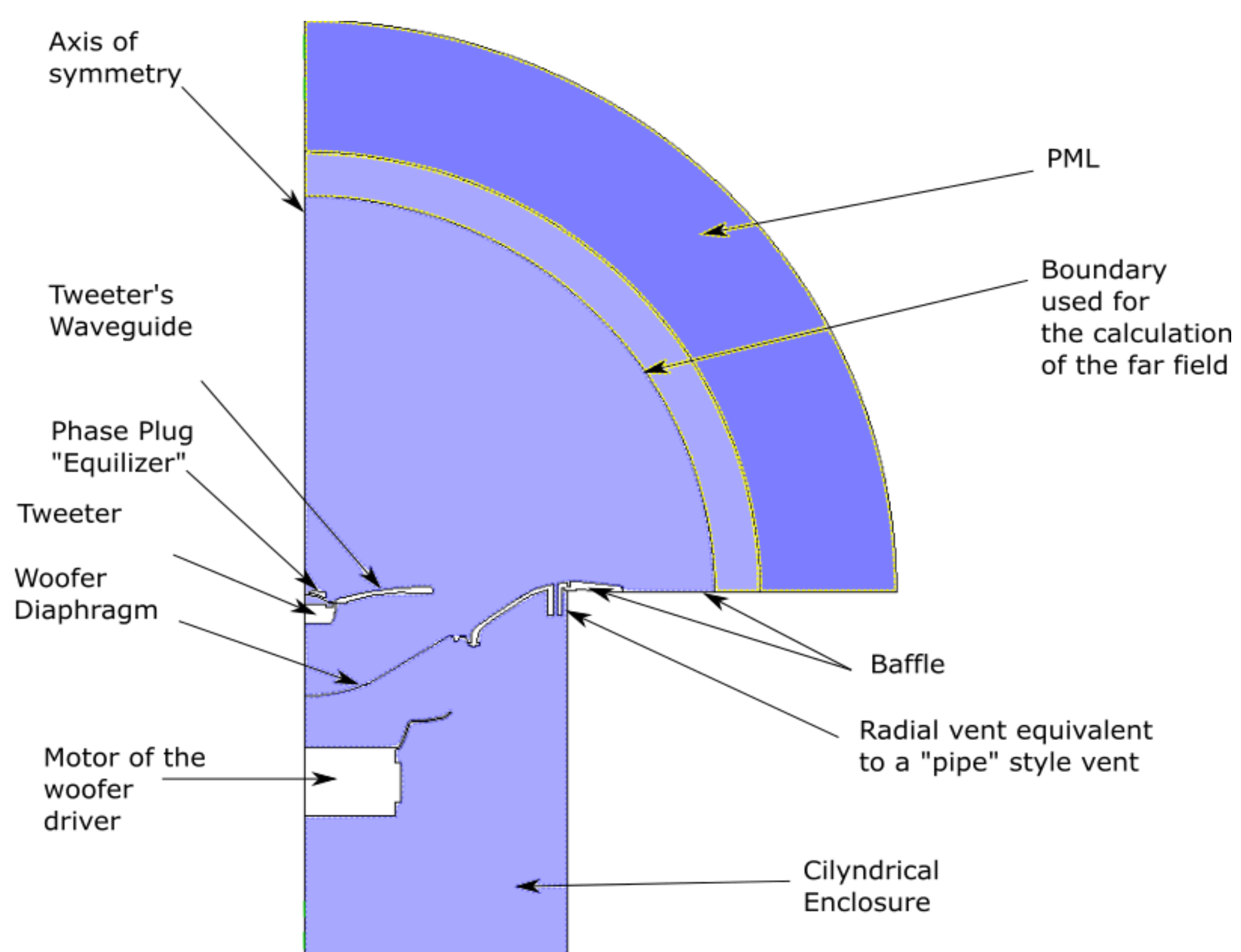

Figure 1. The model

**Computational Methods:** The simulation uses lumped circuit equivalents for the electrical to mechanical domain, (AC/DC module) and then applies the relative acceleration to the diaphragm boundary, where solves the Helmholtz equation (Acoustics module).

$$\nabla \cdot \left( -\frac{1}{\rho_c} (\nabla p_t - q_d) \right) - \frac{k_{eq}^2 p_t}{\rho_c} = Q_m$$

The circuit below is one side involving the woofer side including a second order low pass filter.

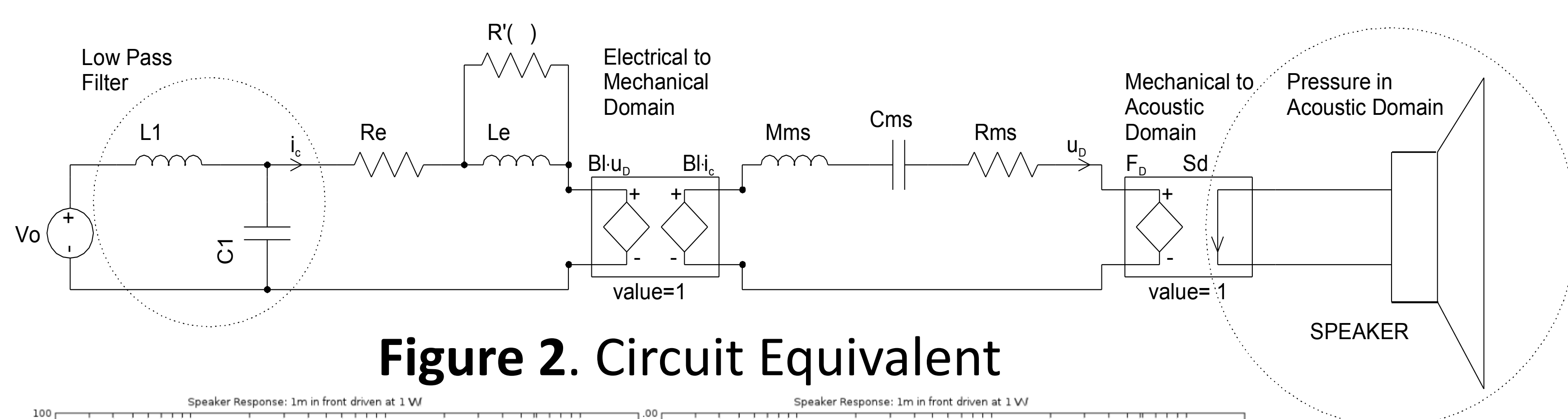

Figure 2. Circuit Equivalent

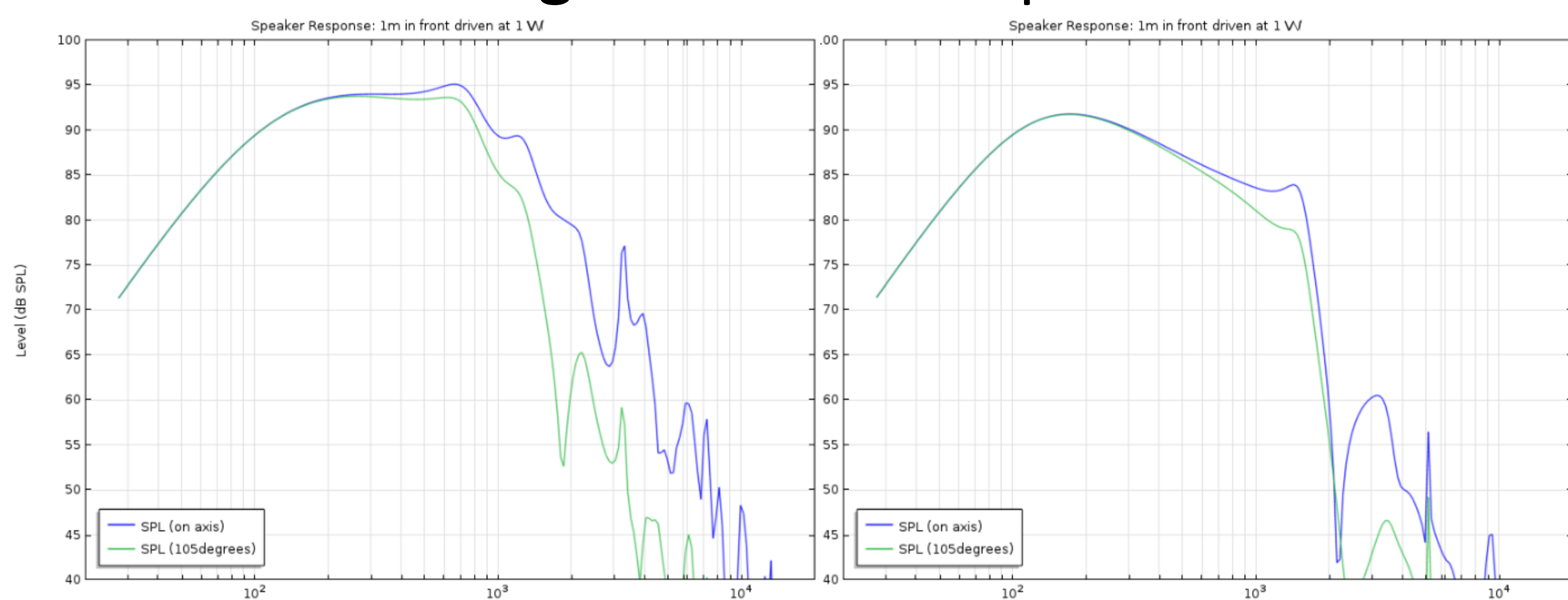

Figure 3. Simulated response for two different woofers and filters

**Results:** The whole system can then be simulated and optimized with the ability to display graphs that are otherwise measured at great cost in terms of resources and time.

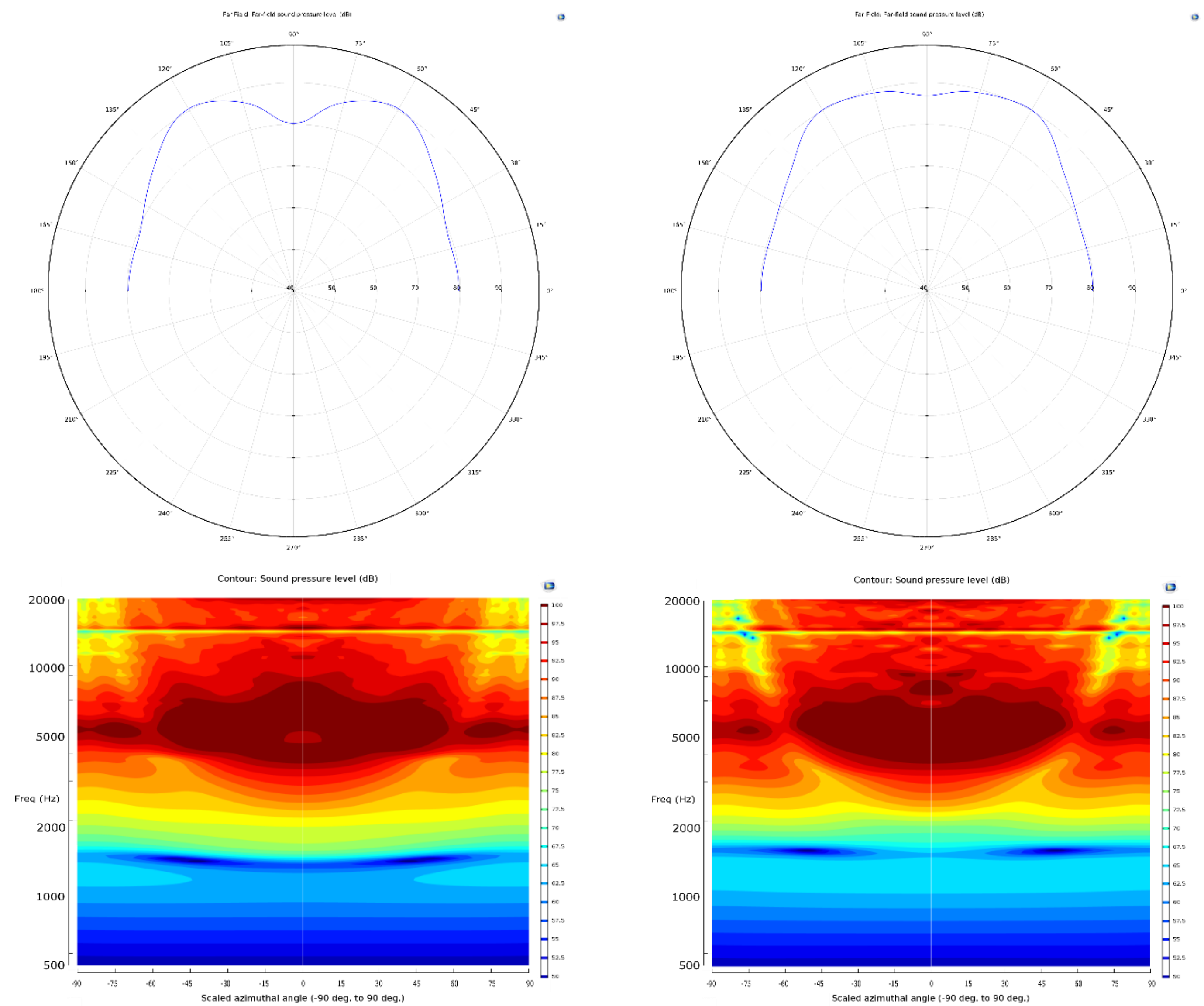

Figure 4. Polar@6.2kHz and mapped response during design before (left) and after optimization (right)

**Conclusions:** Beside being an excellent investigative tool, results of the simulations are close to the measurement cutting prototype work and resource investment.

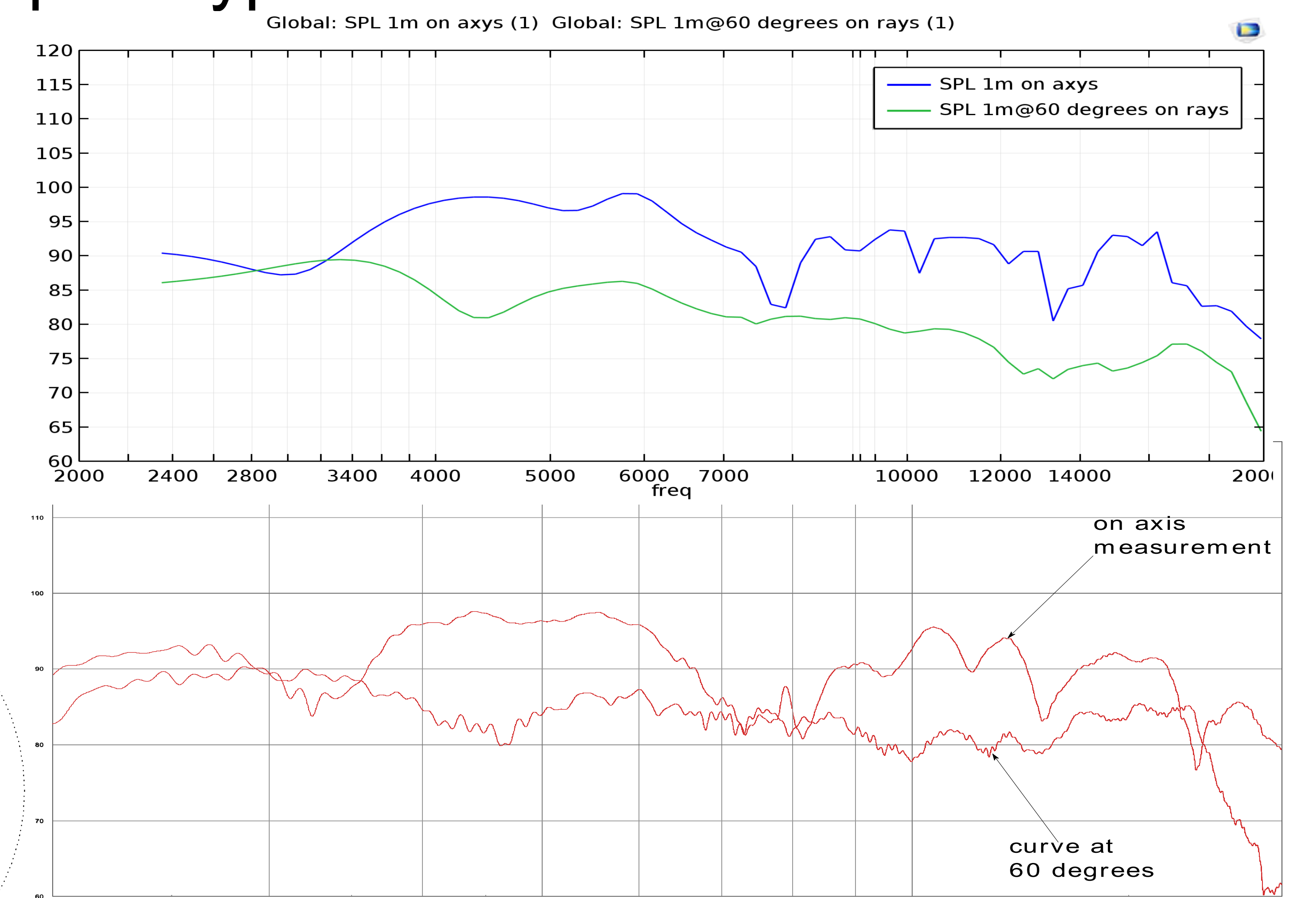

Figure 5. Frequency response comparison

## References:

1. L. L. Beranek, Acoustics, the Acoustical Society of America (1993)
2. A. N. Thiele, Loudspeaker in Vented Boxes Part I, part II, Journal of the Audio Engineering Society, (May-June 1971)
3. COMSOL, Lumped Loudspeaker Driver, Application Library (2014)
4. M. Kleiner, Electroacoustics, CRC Press (2013)